

General dimensions

Units: mm

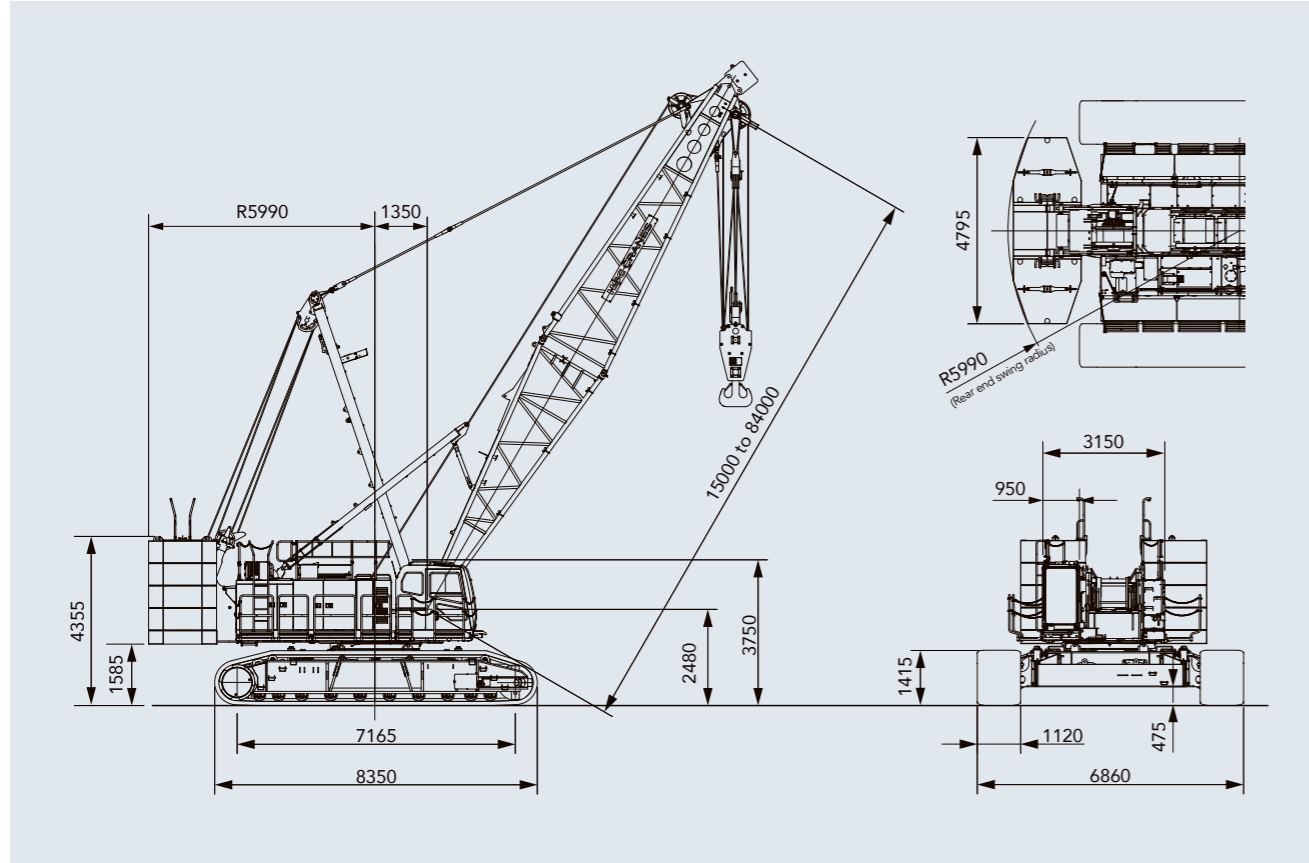

Specifications

Model		SCX1800A-3	
Application		Liftcrane	
		With Heavy Duty Top	With STD Top
Max. lifting capacity	t × m	175 / 180 x 4.1 *1	160 x 4.5
Basic boom length (with heavy duty top)	m	12	—
Basic boom length (with STD top)	m	—	15 (21with auxiliary sheave)
Max. boom length	m	—	84 (78 with auxiliary sheave)
Crane jib length	m	—	13~31
Max. boom + crane jib length	m	—	75 + 31
Rope line speeds *2	Front/rear main drum (rated with 12 t load) m/min	110 (45)	110 (45)
	Boom hoist drum m/min	44	44
Swing speed	min <sup>-1</sup> (rpm)	1.8 (1.8)	1.8 (1.8)
Travel speed high/low *3	km/h	1.1 / 0.6	1.1 / 0.6
Gradeability	% (°)	30 (17)	30 (17)
Engine Make & model		Cummins B6.7 (Stage V)	
Max. output	kW/min <sup>1</sup> (PS/rpm)	209/2,000 (284/2,000)	
Ground contact pressure *4	kPa (kgf/cm <sup>2</sup> )	103 (1.05) w/basic boom, 175 t hook block	102 (1.04) w/basic boom, 160 t hook block
Operating weight *4	t	169 w/basic boom, 175 t hook block	167 w/basic boom, 160 t hook block

Notes: 1. 180 t lifting capacity is limited edition, and requires special equipment (\*1). 2. Rope line speeds vary under load and operating conditions (\*2). 3. Travel speed is based on flat, level and firm supporting surface with no load and basic boom (\*3). 4. Handrail (folding type), with catwalk (\*4).

- We are constantly improving our products and therefore reserve the right to change designs and specifications without notice.
- Units in this catalog are shown under International System of Units (SI). The figures in parenthesis are under the older British Gravitational System of Units.
- Illustrations may include optional equipment and accessories, and may not include all standard equipment.
- Standard equipment and accessories may vary by country and region.

Sumitomo Heavy Industries Construction Cranes Co., Ltd. has been abbreviated as "HSC" throughout this catalog. "HSC CRANES" is a brand of Sumitomo Heavy Industries Construction Cranes Co., Ltd.

Address inquiries to :

Sumitomo Heavy Industries Construction Cranes Co., Ltd.  
 9-3, Higashi-Ueno 6-chome, Taito-ku, Tokyo 110-0015, Japan  
 Phone: 81-3-3845-1387 Facsimile: 81-3-3845-1394  
<http://www.hsc-cranes.com>

Printed in Japan  
 2112©01TEA384

**SCX  
 1800A-3**

Meets European Stage V  
 Non-Road Emission Standards



# Innovative features to brighten tomorrow.

The long-awaited 175 t class crawler crane SCX1800A-3 is finally here to cater to the surge in social infrastructure projects and construction sites around the world. And it comes packed with the wealth of knowledge that HSC has developed over the years as experts of crawler cranes. Now powered with an engine that clears the world's toughest EU Stage V emission regulations, the SCX1800A-3 is even more capable on worksites. The true value of such innovation will shine through the more it is used on tougher worksites. SCX1800A-3...created to build the world of tomorrow. Discover the immense value the crane is capable of across a broader range of applications.

**SCX  
1800A-3**



The Good Design Award has been granted to the "SCX-3 Series" for its superb operability, ease of transportation and assembly, safety, and eco-friendly performance as a new generation of crane.



## SCX1800A-3 PERFORMANCE

### Exceptional capabilities to streamline worksites.

The SCX1800A-3 provides exceptional lifting capabilities with a compact body.

The main boom and crane jib combination has a reach of up to 75 m + 31 m, covering a wide working area to further streamline operations on worksites. An auxiliary sheave (2 sheaves) option is also now available to provide greater lifting performance, catering to increasingly diverse customer requirements.

#### Broad range of attachments

To make the SCX1800A-3 suited to various crane operations, a broad range of attachments are available to suit different types of work. Specifications can be tailored to suit customer requirements, including a HD boom for heavy duty lifting, the highly versatile standard boom, or crane jib for working over a wider area.

#### Auxiliary sheave (2 sheaves) OPTION

Lifting capabilities can be doubled over one auxiliary sheave by selecting the two-auxiliary sheave option, to suit a broad range of work requirements (set with standard boom, boom length at 21 to 78 m).

#### Standard boom

Maximum lifting load (rated)  
**160 t x 4.5 m**  
Maximum boom length  
**84 m**

#### HD boom

Maximum lifting load (rated)  
**175 t / 180 t\* x 4.1 m**

\*180 t lifting capacity is limited edition, and requires special equipment.

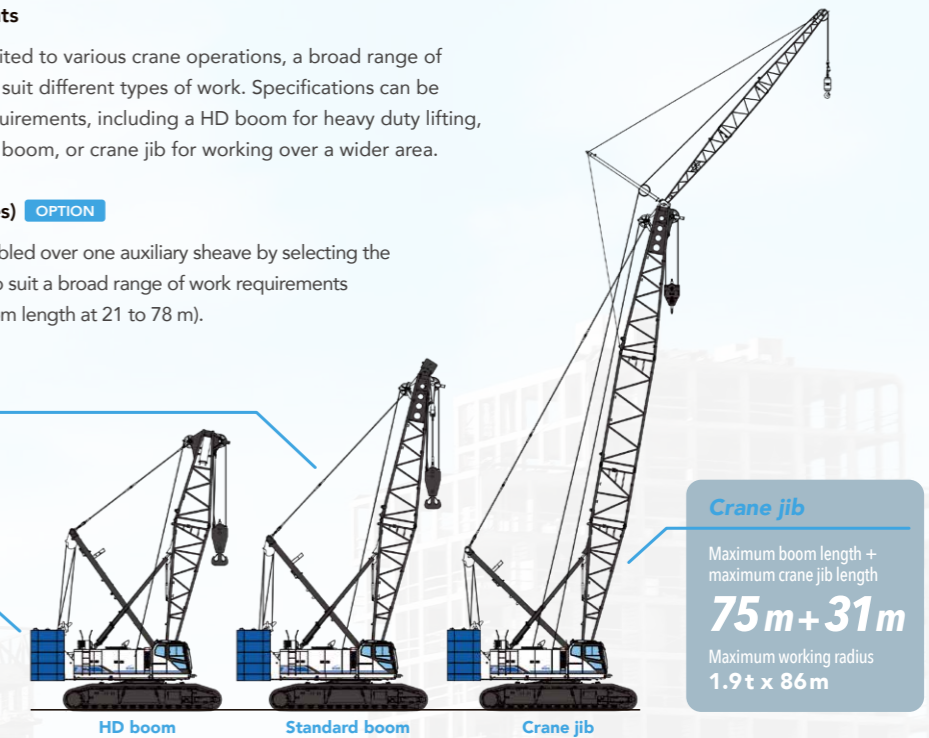

#### Powerful winch

A 12 t rated line pull winch is included, providing a 45 m/min line speed with a rated 12 t load for ample performance during heavy duty work or simultaneous movements. And when accompanied with the optional brake that provides a better operating feel, the result is superior workability. A winch with free fall function is also available as an option.

A 13.5 t rated line pull winch (rope  $\phi$ 28 mm) is optionally available.

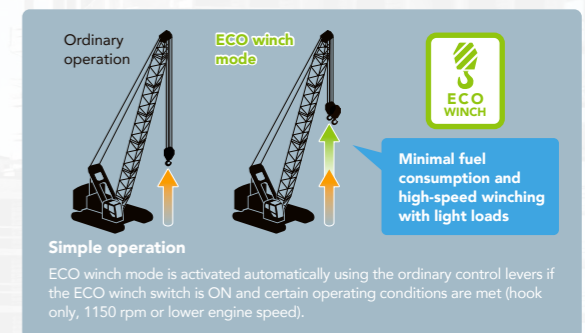

#### Eco winch mode with high-speed winching and low-fuel consumption

Also included is a new Eco winch mode, which allows high line speeds under light loads without having to increase the engine speed (low rpm). This mode delivers outstanding workability in situations such as high-elevation construction sites and multiple rope hanging operations and also limits fuel consumption and noise as engine speed can be kept at a minimum.

## SCX1800A-3 CONTROL

### High-precision, exactly as intended. A level of control available to all.

Flexible operation and performance makes the crane truly shine during heavy lifting or precision jobs. The crane has been designed so that it can be operated by anyone, exactly as they intend to, instead of relying on the operator's level of experience or skill. Outstanding usability has been the key behind development, and can be experienced at your work site, wherever in the world that may be.

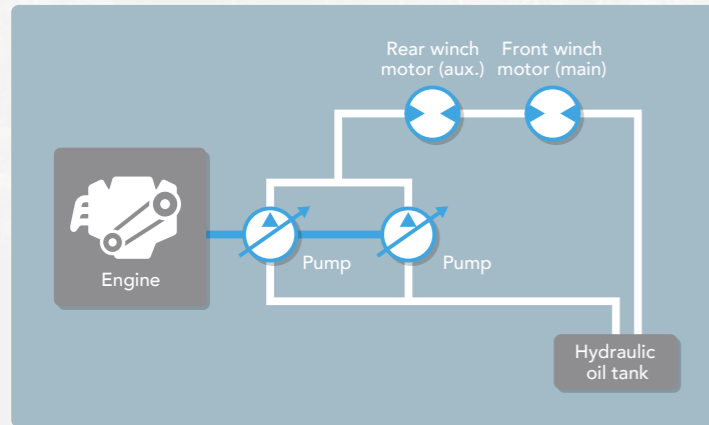

#### Combined hydraulic circuits

The hydraulic system uses HSC's own unique combined hydraulic circuit. By increasing and optimizing the pump pressure through the use of a mixed circuit to control the hydraulic oil from two hydraulic pumps, the sense of operability in travelling, hoisting/lowering, swing and boom hoisting can be enhanced. Even for multiplex operations, the latest hydraulic control system is able to support all tasks efficiently through priority control matching the needs. This helps to achieve a sense of operability that matches the intent of the operator.



#### New multiple wet-disc type brake with improved control feel **OPTION**

The optional brake uses a new multiple wet-disc type that offers better control. A hanging brake pedal gives the operator smooth and precise response. Reliable braking performance is now a reality even under high loads, all while minimizing disc temperature. The system can even be used for heavy digging and foundation work that utilizes free-fall operation\*.

\*Free-fall function is an optional extra for models equipped with the 12 t rated line pull winch. See the Spec. catalog for more details.



#### Control dials

Fine speed control dials for operations such as hoisting, lowering, swinging and boom hoisting are positioned in a central location on the left side console. Operations can be adjusted at will to suit the particular job.

#### Swing neutral brake **OPTION**

Switches for swing free/swing brake when the control lever is in the neutral position have been installed. When the swing lever is in the neutral position, the operator may choose between free or brake depending on the work and personal preferences.



#### Swing brake operation pedal **OPTION**

A swing brake operation pedal has been employed to ensure precise swing control under strong-wind situations. This maintains a high level of control when swinging the cab around, even on the harshest of work sites.





Photos may differ to the specifications of available products.

## SCX1800A-3 TRANSPORTABILITY

### Speedy and smart. Exceptional transportability and assembly guarantees better results.

The crane represents exceptional value when transporting it between sites. Performance has been retained while offering a design that allows efficient transportation, assembly and disassembly. This level of transportation and assembly combine to drastically improve efficiency on any work site.

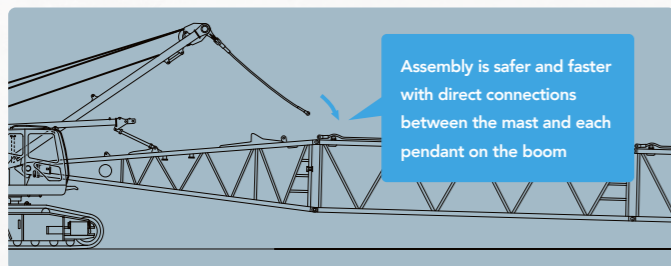

Assembly is safer and faster with direct connections between the mast and each pendant on the boom

#### Redefining the assembly and disassembly process with the mast system

The use of a mast system that allows the entire mast to be lowered with the upper spreader structure drastically improves pendant joint work and the boom assembly process. Other features such as similarly shaped counter weight make assembly and disassembly processes easier, while labor-saving hydraulic hose connections and safe operation mean the crane is an all-round winner when it comes to assembly.

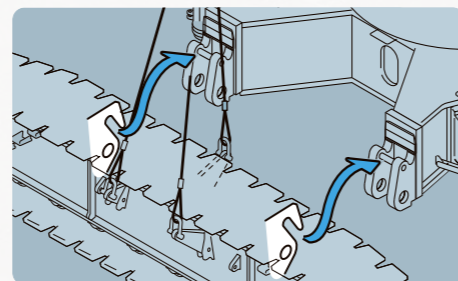

#### Hook-on and joint pin design for crawler side frame assembling

A detachable crawler side frame system designed for easy attachment and removal has been used. Simple structure, quick-release cylinders are designed to make assemble/disassembly easier, with a priority placed on safety during assembly.



Counter weights and boom can be transported together

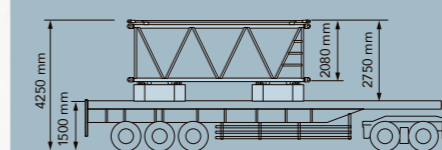
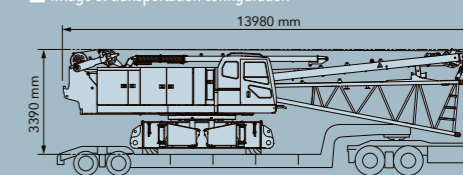

Image of transportation configuration



#### Identical counter weight shapes





The counter weights are of identical shapes (excluding the base weights) for the left and right sides, to help ease the assembly process. The weights can be stacked on either side and in any order, ensuring assembly can be completed quicker. This symmetrical design also enhances efficiency during transportation—the height of individual weights has been made lower so that they can be transported together with the boom insert (transportation must comply with the relevant regulations of each country).

#### Transportation weight of just 40.8 t

The total weight during transportation—including the lower boom, winch rope and mast—has been kept to 40.8 t (crane body itself at 27.6 t), while also remaining within a 3.2 m transportation width.

#### Reduction counter weight specification OPTION

Reduction counter weight specification are available as an optional extra to provide added flexibility for a diverse range of worksites, including high locations and within tight internal areas where operating weight is limited or restricted (with counter weight detector).

Counter weight	 Std	 -1 layer	 -2 layers	 -3 layers
Total operating weight	169 / 167 t	153 t	139 t	126 t
Ground contact pressure	103 / 102 kPa	93.2 kPa	85.3 kPa	76.5 kPa

Note: Reduction counter weight specifications are configured to suit crane specifications excluding the crane jib.

#### Designed for ease of transportation and assembly

- [Transportation]
- Crane can be loaded directly on the trailer without wooden blocks
  - Lashing lugs during transportation
  - Storage lugs for hydraulic hoses of traveling device
  - Lugs for boom lifting
- [Assembly]
- Multi-assembly stage monitoring system
  - Boom foot pin positioning guide
  - Boom foot pin removal/installation cylinder OPTION
  - Hydraulic shoe tension unit OPTION
  - Boom connect pin storage compartment
- [Other]
- Remote control box storage for jack with car body

## SCX1800A-3 SAFETY

### Reliable and precise lifting with advanced safety features

Improving safety should come first and foremost. A simple, easy-to-view interface has been designed to ensure that information is provided to the operator in the most reliable way possible. Various accident prevention measures and multiple redundant safety devices have also been included to provide comfort for the operator. Rest assured that your work is safe, backed with a full complement of advanced safety equipment.

#### Moment limiter display (Stage IV / Tier IV f compliant model)

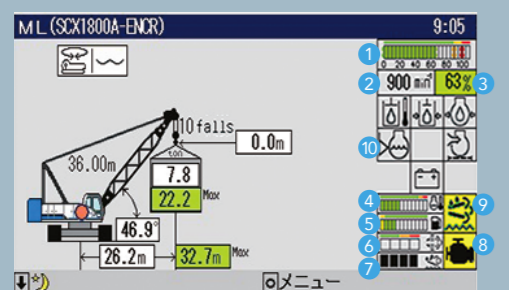

- |                                      |  |
|--------------------------------------|--|
| 1 Load ratio indicator (%)           | 6 Soot level gauge                     |
| 2 Engine speed                       | 7 Urea fluid gauge                     |
| 3 Load ratio (%)                     | 8 Engine trouble alarm (yellow or red) |
| 4 Water temperature (engine coolant) | 9 Urea SCR system display              |
| 5 Fuel gauge                         | 10 Warning icons                       |

#### Moment limiter with large screen display

A large screen display has been used offering excellent visibility and field of view of any job. A host of items can be shown, while a simple display layout ensures that information is provided to the operator properly. The display has also been designed with an interactive interface to follow any movement of the crane from a safety perspective, which helps to limit unintended operations and maintain utmost safety.

#### ML Anti-two block

A new anti-two block using a lifting height indication device is offered as a standard equipment. When a height restriction is set in advance in the lifting height meter, the slowdown function will kick in as the restricted height is approached to prevent hook overhoist. Together with the anti-two block switch, the lifting height moment limiter provides a redundant level of safety against hook overhoist, leading to improved safety.

Note) This function plays a supplementary role to the existing moment limiter and use of this equipment alone is prohibited by laws and regulations.

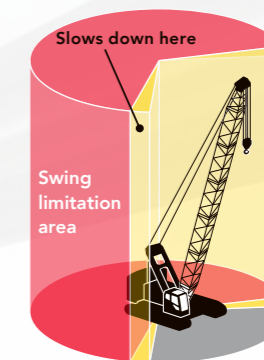

#### Swing restriction unit OPTION

This device prevents the crane from swinging into objects and causing damage, by notifying the operator of the swinging range and automatically stopping the crane when required. The result is an added level of safety when working in tight areas.



#### Drum and rear view monitor system OPTION

A drum and rear view monitor system is available to help check winching and conditions behind the crane. The wide screen has been designed for ease of viewing, and can switch between cameras to make checking the operation of each section easier.

#### Designed for safe work

An auto drum lock is installed as standard, which detects boom hoisting operations and automatically applies the lock when the lever is in the neutral position. Various warning alarms and information are conveyed to the operator to help reduce the number of careless accidents. The width of the skywalk (optional extra) has been increased to make assembly easier, and a catwalk with handrails and upper house handrails (folding type) are also installed as standard. All these combine to ensure work is conducted as safely as possible.



Skywalk (made by FRP) OPTION



Catwalk with handrails and folding type upper house handrails

#### Other safety functions and devices

- Winch drum lock (front, rear)
- Individual winch operation lever locks
- Three color percentage indicator OPTION
- Anti-two block
- Gate lock lever
- Firewall
- Emergency engine stop switch

### Clean-running and energy-efficient. Eco-friendly performance transforming society.

Machinery creating tomorrow's foundations are built on the leading technology available today. The SCX1800A-3 brings together a new cleaner running engine and advanced control system (ECO winch mode, auto idle stop function) for energy-efficient operation. This combination clears EU Stage V exhaust gas emission regulations, thereby boosting the capabilities of the SCX1800A-3 over a broader range of jobsites, while also bringing exceptional fuel efficiency and outstanding operation and control.



#### New clean engine

Powered with a new-generation Cummins engine that meets EU Stage V emission standards for the highest level of clean running performance. With an ideal balance between ultra-low exhaust emissions and superb fuel efficiency, the crane is now a seamless fit for any job site and social environment.

#### Engine specifications

Emissions regulation	EU Stage V
Engine manufacturer/model	Cummins / B6.7
Displacement	6.7 L
Rated power output	209 kW (284 PS) / 2000 min <sup>-1</sup>
EGR System	N/A
Exhaust gas aftertreatment device	Muffler filter + urea SCR

#### Excellent fuel economy for low-cost operations

Powered by the latest high-efficiency engine, and equipped with an advanced ECO winch and auto idle stop function to perform operations using less fuel. Unnecessary fuel consumption has been reduced significantly so that there is less impact on the environment, while low-cost operations ensure greater earning potential for customers.

#### Low-noise operations

Acquired Low Noise Construction Machinery certification in Japan, ensuring less noise disruptions in areas surrounding construction sites.

#### Outline of EU Emissions Standards

The new Stage V emission standards came into effect in the European market from 2019. In addition to standards for existing emissions such as PM and NOx, Stage V also introduces restrictions for the PN (Particulate Number). Even more advanced exhaust post-processing systems are required to meet the toughest emission standards in the world.

#### Enhanced engine performance

In addition to running cleaner, the system also improves rated power output and medium-range torque of the engine (compared to Stage IV engine specifications).

#### Single-module design

The exhaust post-processing system features a compact, single-module design for greater performance and ease-of-installation.

#### High-capacity urea tank

The use of a high-capacity urea tank (85 L) helps to enhance convenience.

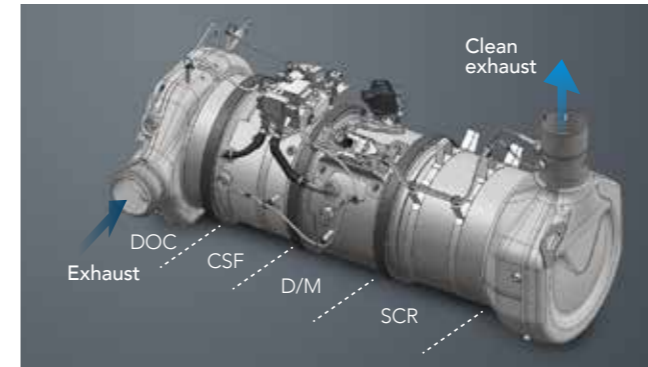

#### Precautions with the new clean engine

- Always use diesel for the fuel, specified lower ash oil (E6, E9 (ACEA) class) for the engine oil, and specified engine coolant. The CSF + Urea SCR System may undergo automatic regeneration (cleaning) to maintain its performance level.

#### Muffler filter + Urea SCR

Exhaust post-processing systems consist of a muffler filter and urea SCR. The preliminary stage muffler filter reduces PM, while the subsequent stage urea SCR cuts down on NOx emissions. The urea SCR device sprays AdBlue® (urea solution) to decompose NOx into harmless water and nitrogen through chemical reaction.

AdBlue® is a registered trademark of the German Association of the Automotive Industry.

#### Other fuel efficiency technology



Minimizes excess fuel consumption during work  
Auto idle stop function



Greater work efficiency by minimizing unnecessary movement with light load work  
ECO winch mode (refer to P. 5 for details)

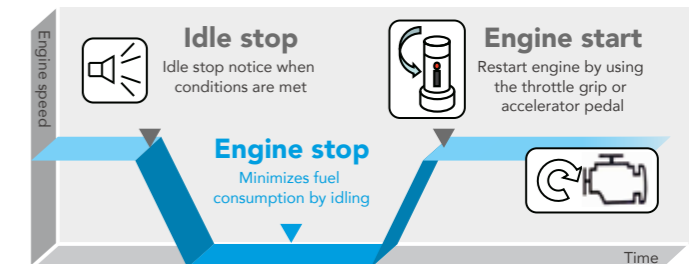

#### What is AdBlue®?

The trademark of a high-quality urea aqueous solution standardized in Europe for using the Urea SCR System.



AdBlue® is a registered trademark of the German Association of the Automotive Industry.

#### Refilling frequency Once per two refuelings

The SCX1800A-3 requires AdBlue® to be refilled once every two times the machine is refueled.

(AdBlue® consumption may vary slightly depending on operating conditions)

#### Precautions with machines installed with the Urea SCR System

To ensure that the machine can be used safely and smoothly, use AdBlue® aqueous solution (or a urea aqueous solution that complies with JIS or ISO standards). Using a non-standard aqueous solution or diluting the solution before use may cause mechanical problems. Malfunctions arising from the use of non-standard aqueous solutions are not covered by the HSC warranty service.

- The remaining AdBlue® level can be checked during work on the monitor display (Moment Limiter) in the cab. A warning is displayed on the monitor when the remaining level becomes low or there is an issue with quality.
- The engine power output will be limited if the remaining AdBlue® level falls below the minimum level or there is an issue with quality, so be sure to plan refills in advance.
- The Urea SCR System is designed exclusively for the machine, and must not be used for any other purpose.
- Rinse with water any solution that comes in contact with skin.
- When storing the solution, always use sealed containers and store at room temperature in a well-ventilated location out of direct sunlight. When carrying the solution, always use the container that the solution was purchased in, or other specified container.
- The Urea SCR System includes a heater function, however sufficient care must be taken to prevent freezing when the solution is stored in cold regions (freezing temperature: -11°C)
- Read the instruction manual for more details.

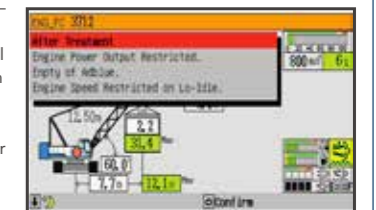

Example monitor warning display

### Enhanced visibility and functionality with greater comfort.

To provide operators with greater comfort over a longer work span, HSC has designed the crane to be easy to use from the ground up. Design elements such as excellent visibility and an optimum working position help to reduce operator fatigue, while at the same time increasing comfort and functionality to ensure maximum performance, day-in, day-out.



#### Major improvements to operating field of view

The cab has extra-wide windows to improve visibility in all directions. Green tinted safety glass has been used all round to protect the operator from UV rays and objects that may have come free during operation. A new wiper provides a greater area of visibility when working in rain.

#### Highly functional seat for optimum work position

The new seats are designed with the ideal shape for a more comfortable seating position. The wide range of seat adjustments means it suits any body shape, for the best work and a relaxing posture. A seat with suspension is available as an optional extra.



#### Large sliding door

A sliding door and wide platform have been implemented to reduce the amount of space required when opening and closing the door, which makes getting in and out of the cab a breeze. Four steps on the side of the crawler side frame have been used for even better access.



#### Optimized lever and switch layout

The pitch of the armchair levers can be optimized to improve operation with an intelligent and ergonomic switch layout.



#### Cross operation lever OPTION

Cross operation lever is provided for a good, easy and comfortable operation for two main operating drums, boom hoist drum and swinging. For travel motion, two armchair levers are provided behind right-hand cross operation lever for operator comfort.

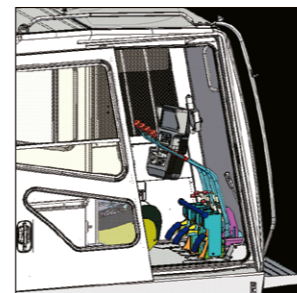

#### Front operation lever (with lever lock) OPTION

A front operation lever is also available as an option to suit operator preferences or customer job requirements.

# Exceptional peace of mind and convenience for worksites.

## REMOTE SENSING

### Newly developed "REMOTE SENSING" system installed as standard

Precise monitoring of the crane's operating condition to minimize downtime and ensure accurate maintenance. Keeping machines in the best possible operating condition helps to improve operating efficiency, while also reducing the time and cost required for maintenance.

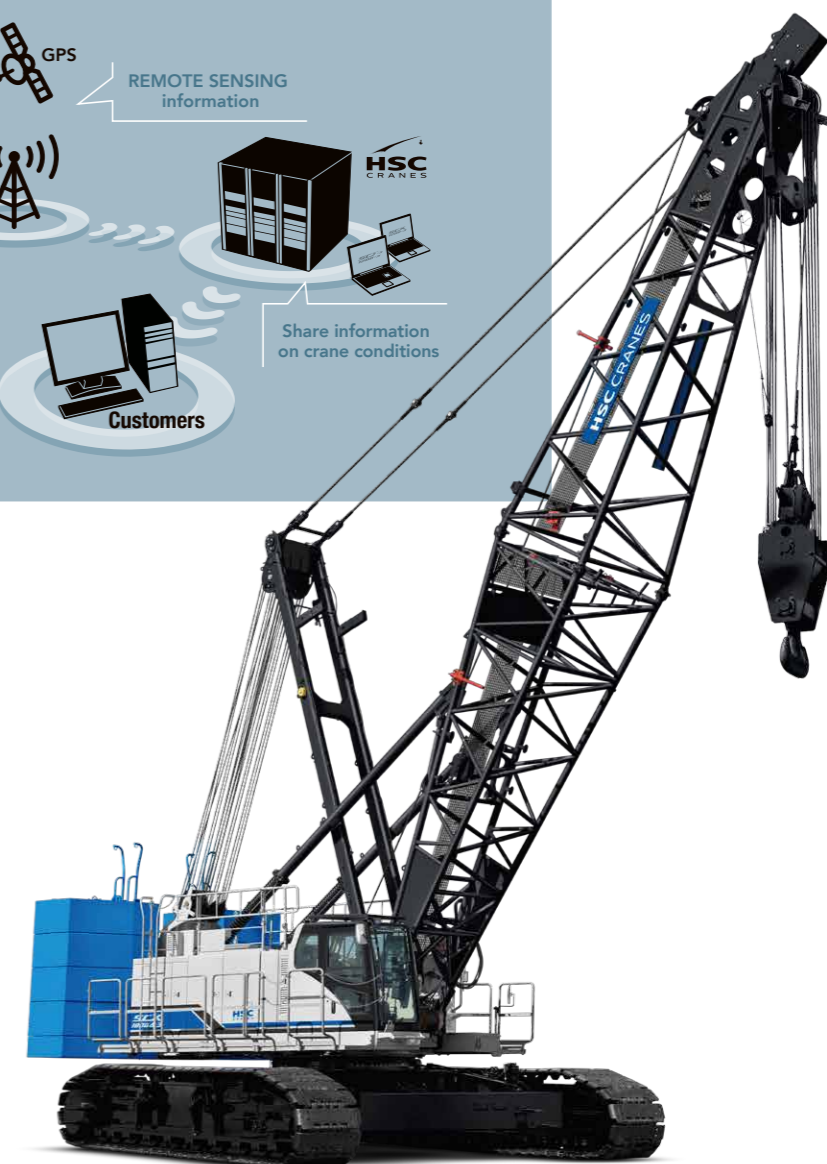
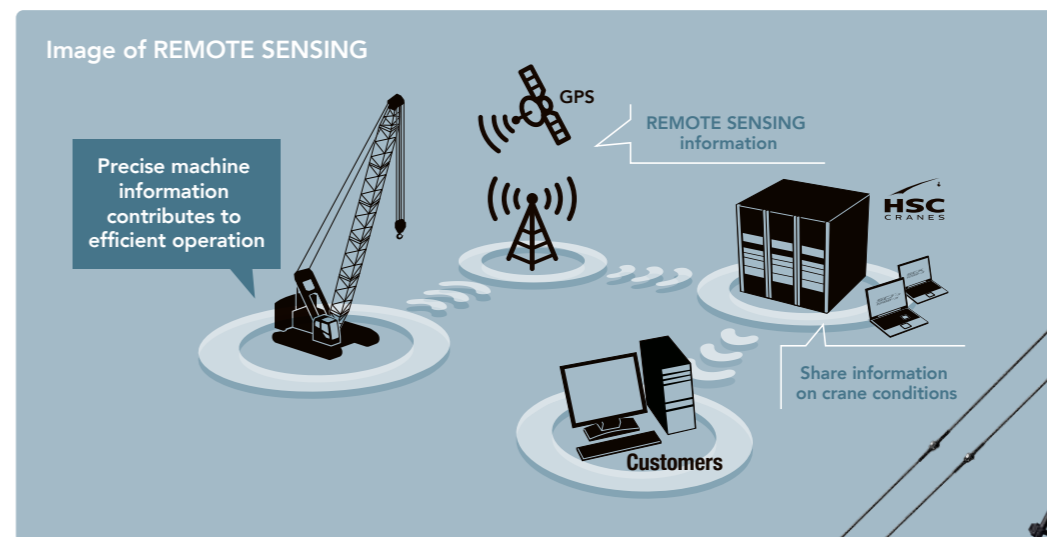
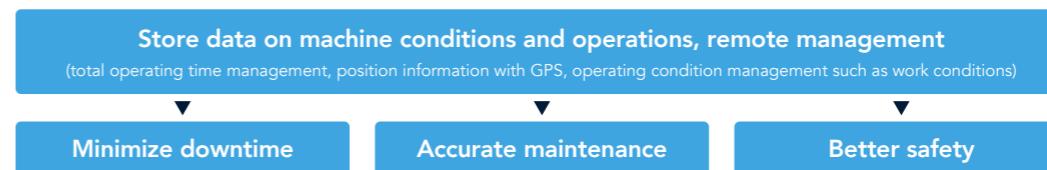

\*Photos may differ to the specifications of available products.